

HYDRAULIKA

ISO 6020/2

ZN 160.2

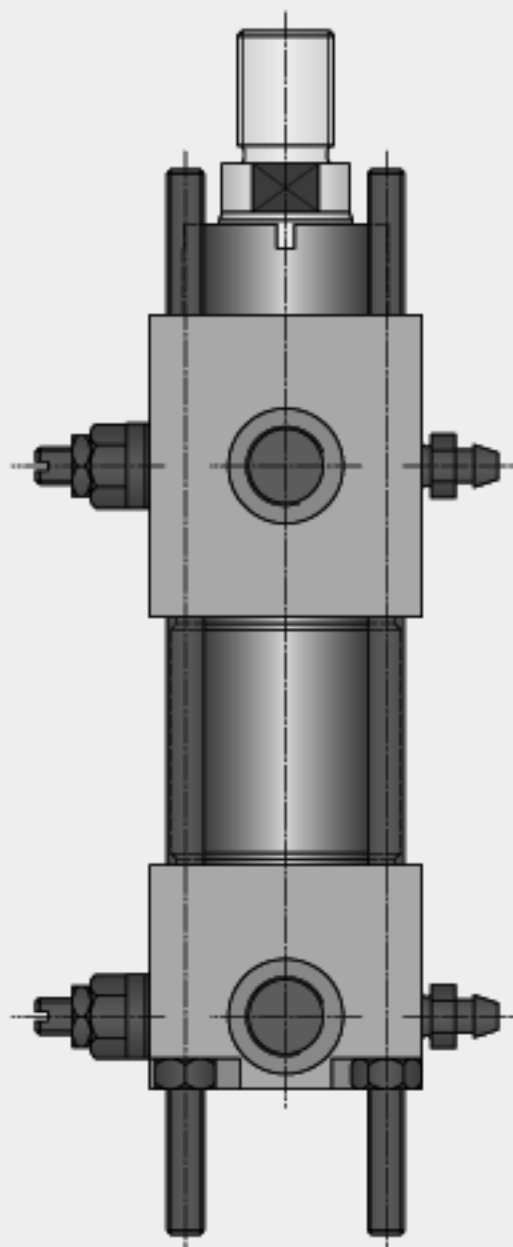
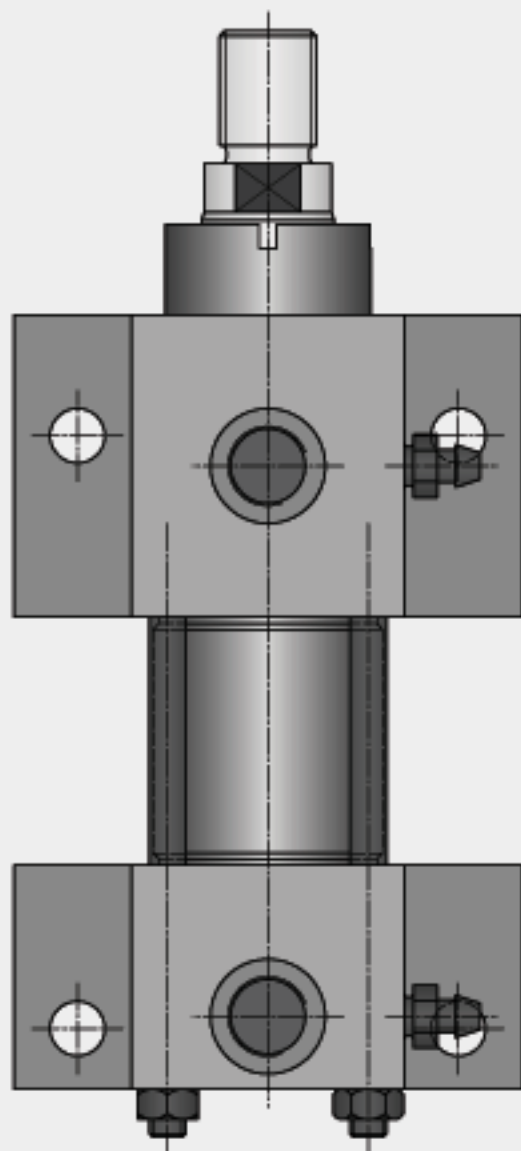

Hydraulika GmbH
Stübeweg 54
D - 79108 Freiburg

Tel.: +49 (0) 761 / 504710
Fax.: +49 (0) 761 / 5047199

e - mail : info@hydraulika.de

Alleinige Herstellerin der
Markenerzeugnisse

HYDAIR[®]

Universalzylinder für Luft- oder Ölbetrieb
Universal cylinder for air or hydraulic operation
Cylindre universel pour service d'air ou service hydraulique

Hydraulikzylinder
Hydraulic cylinder
Cylindre hydraulique

DIN / ISO - Zylinder
DIN / ISO - Cylinders
DIN / ISO - Cylindre

Zylinder mit induktiver Endlagenabfrage
Cylinders with inductive proximity sensors
Cylindres avec détecteurs de proximité inductifs

Zylinder mit Wegmess - Systemen
Cylinders with position transducer
Cylindres avec transducteur de position

Pneumatikzylinder
Air cylinder
Cylindre à air

Block - und Einschraubzylinder
Block - and Screw-in Cylinders
Monobloc - et Cylindres à visser

Sonderzylinder auf Anfrage
Special Cylinders on request
Cylindres spéciaux à demande

Drehantriebe pneumatisch bzw. hydraulisch
Rotating drives for pneumatic or hydraulic
Mécanismes de commande rotatifs pneumatique ou hydraulique

Druckübersetzer pneumatisch - hydraulisch
Pressure intensifier
Transformateur de pression

Verbindungselemente / Zubehör
Connecting parts / Fittings
Éléments de fixation / Accessoires

Die Hydraulika Normzylinder ZN

Baureihe ZN 160.2 entspricht in allen Belangen und Anforderungen der internationalen Normung für Hydrozylinder

ZN 160.2 - 160 bar - ISO 6020 / 2

Alle Zylinder sind wahlweise mit oder ohne Endlagendämpfung lieferbar, wobei die Einbau abmessungen gleich bleiben. Die Endlagendämpfung ist ab Kolben-Ø 40 serienmässig regelbar mit freiem Rücklauf.

Entlüftungsschrauben serienmässig

Durch das Baukastenprinzip sind nahezu alle Befestigungsteile mit dem Grundzylinder montierbar, dadurch ist auch die Lieferung von Zylinder- Einzelteilen (Komponenten) zur Selbstmontage möglich.

Die Hublängen werden nach Kundenwunsch gefertigt, dabei ist jedoch die Knickbelastung der Kolbenstange gemäss Diagramm zu beachten.

Zu jedem Kolben-Ø sind wahlweise zwei Stangen-Ø lieferbar. Die Kolbenstangen- gewinde sind zum Anbau der passenden Gelenkköpfe vorgesehen.

Die Kolbenstangen werden standardmässig aus Vergütungsstahl mit hartverchromter Oberfläche gefertigt - auf Wunsch auch induktivgehärtet und hartverchromt lieferbar.

Alle Zylinder sind standardmässig mit PUR - Nutring als Stangendichtung, PTFE- Gleitring-Dichtsatz als Kolbendichtung, sowie reibungsarmen und verschleissfesten PTFE - Compound-Führungselementen ausgerüstet. Andere Dichtungsvarianten sind auf Wunsch lieferbar.

Betriebsmedium Mineralöl nach DIN 51524 und DIN 51525. Bei anderen Druckmedien wird um Rücksprache gebeten.

Betriebstemperaturbereich
-35°C bis +110°C

Max. Gleitgeschwindigkeit 0,5 m/s

Andere Ausführungen auf Anfrage.

The Hydraulika

Standard Cylinders ZN

Serie ZN 160.2 completely fulfill the requirements of the international Standards for Hydraulic cylinders:

ZN 160.2 - 160 bar - ISO 6020 / 2

As required, all cylinders are available with or without final position damping, with the installation dimensions remaining the same. As standard, the final position damping is adjustable on piston- diam. 40, with free return.

Venting bolts standard

Due to the modular principle, virtually all mounting parts can be fitted with the basic cylinder, and it is thus possible to supply individual cylinders parts (components), for self- assembly.

The stroke lengths are made according to the customers requirements, provided the strain resistance of the piston rod is observed, according to the diagram.

For each piston dia., two rod diameters are available, as required. The piston rod threads are designed for the fitment of suitable articulated heads.

As standard, the piston rods are manufactured from heat treated steel with hardchromium plated surface, on request, induction hardened and hardchromium plating is also available.

As standard, all cylinders are fitted with a PUR groove ring as the rod seal, PTFE slide ring packing as the piston seal, as well as low- friction, wearresistant PTFE compound guide elements. Other sealing variants are available on request.

Operating medium Mineral oils according to DIN 51524 and DIN 51525. Please contact us if you like to use other fluids.

Operating temperature range
-35°C to +110°C .

Max. rubbing speed 0,5 m/s

Other versions are possible on request.

Les cylindres standard

Hydraulika ZN

des série ZN 160.2 correspondent sous tous les aspects aux exigences des normes internationales relatives aux cylindres hydrauliques :

ZN 160.2 - 160 bar - ISO 6020 / 2

Tous les cylindres peuvent être livrés, à choix du client, avec ou sans amortissement de positions finales, les dimensions restant toujours les mêmes. L'amortissement des positions finales est réglable sur tous les types de série; recul libre.

Vis de purge d'air

Grâce au principe modulaire, presque tous les éléments de fixation peuvent être montés avec le cylindre standard; ce système-là permet aussi la fourniture d'éléments individuels de cylindres (composants) à monter par le client même.

Les longueurs de course seront adaptées aux besoins du client, tout en tenant compte de l'effort de flexion auquel sera soumise la tige du piston et qui résulte du schéma.

Chaque Ø de piston peut être combiné avec deux Ø de tige. Les filets des tiges de piston sont destinés à recevoir les têtes articulées correspondantes.

Les tiges de piston standard sont fabriquées d'acier trempé à surface au chromage dur; à demande du client, fabrication par trempe inductive et chromage dur.

Tous les cylindres sont équipés, en série, d'anneaux à rainures PUR servant de garniture de la tige, d'anneaux de glissement PTFE servant de garniture de piston, et d'éléments de guidage compound PTFE à faible frottement et résistants à l'usure. Autres types de garnitures livrables à demande.

Operating medium Mineral oils according to DIN 51524 and DIN 51525. Please contact us if you like to use other fluids.

Températures de service:
de -35°C à +110°C .

Vitesse de glissement max.: 0,5m/s

Des autres modèles à demande.

Bestellbeispiel / Order example / Exemple de commande

ZN 160.2 - ME-6 40 / 28 / 125 Dbb

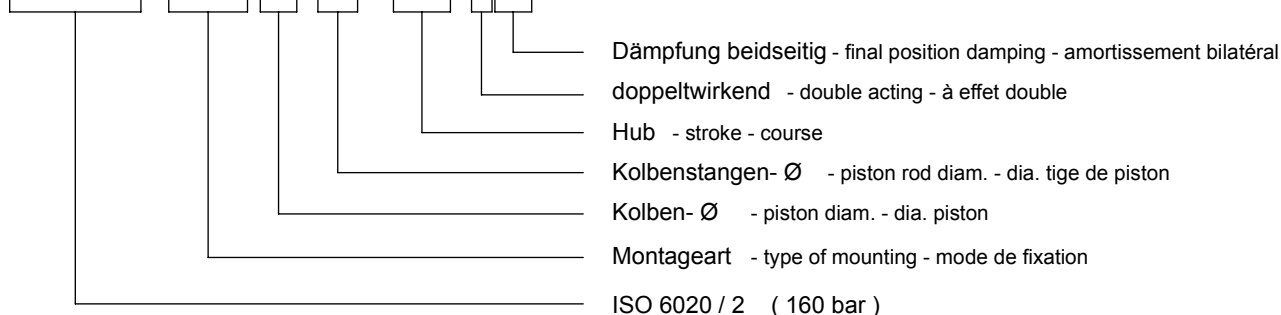

Copyright by Hydraulika GmbH

Nenn-Ø		25		32		40		50		63			
MM-Ø		12	18	14	22	18	28	22	36	28	45		
cm ²	Kolbenfläche	4,9		8,0		12,6		19,6		31,2			
	Kolbenringfläche	3,8	2,4	6,5	4,2	10,0	6,4	15,8	9,5	25,0	15,3		
		Hub = 0				Stroke = 0				Course = 0			
A	A h15	14	18	16	22	18	28	22	36	28	45		
	AA	40		47		59		74		91			
B	B f9	24	30	26	34	30	42	34	50	42	60		
	BB	19		24		35		46		46			
	BD	20		25		30		40		50			
C	CB	12		16		20		30		30			
	CD	10		12		14		20		20			
	CW	6		8		10		15		15			
	CX	12 -0,008		16 -0,008		20 -0,008		25 -0,010		30 -0,010			
D	D	10	15	12	18	15	22	18	30	22	39		
	DD	M5		M6		M8x1		M12x1,25		M12x1,25			
E	E	40		45		63		75		90			
	EE	G 1/4"		G 1/4"		G 3/8"		G 1/2"		G 1/2"			
	EP h15	8		11		13		17		19			
	EW h14	12		16		20		30		30			
	EX	10 -0,12		14 -0,12		16 -0,12		20 -0,12		22 -0,12			
F	F	10		7		10		16		16			
	FB H13	5,5		6,6		11		14		14			
G	GF	35		40		40		48		48			
H	H	45		50		-		-		-			
J	J	25		25		38		38		38			
K	KK	M10x1,25	M14x1,5	M12x1,25	M16x1,5	M14x1,5	M20x1,5	M16x1,5	M27x2	M20x1,5	M33x2		
L	L	13		19		19		32		32			
	LH h10	19		22		31		37		44			
	LT	16		20		25		32		38			
M	MM	12	18	14	22	18	28	22	36	28	45		
	MR	12		17		17		29		29			
	MS	20		22		29		33		40			
N	NA	11	17	13	21	17	26	21	34	20	43		
P	PJ ±1,25	53 + Hub		56 + Hub		73 + Hub		74 + Hub		80 + Hub			
R	R js13	27		33		41		52		65			
	RD f8	38		42		62		74		75	88		
S	SB H13	6,6		9		11		14		18			
	SS ±1,25	73 + Hub		73 + Hub		98 + Hub		92 + Hub		86 + Hub			
	ST	8,5		12,5		12,5		19		26			
T	TC h14	38		44		63		76		89			
	TD f8	12		16		20		25		32			
	TG	28,3		33,2		41,7		52,3		64,3			
	TM h14	48		55		76		89		100			
	TO js13	51		58		87		105		117			
	TS js13	54		63		83		102		124			
U	UM	68		79		108		129		150			
	UO	65		70		110		130		145			
	US	72		84		103		127		161			
	UT	58		68		95		116		139			
	UW	63		75		92		112		126			
V	VD min.	5		5		5		5		5			
	VE	16		22		22		25		29			
W	WF ±2	25		35		35		41		48			
	WH ±2	15		25		25		25		32			
X	XC ±1,25	127 + Hub		147 + Hub		172 + Hub		191 + Hub		200 + Hub			
	XG	44		54		57		64		70			
	XJ	101 + Hub		115 + Hub		134 + Hub		140 + Hub		149 + Hub			
	XO ±1,25	130 + Hub		148 + Hub		178 + Hub		190 + Hub		206 + Hub			
	XS ±2	33		45		45		54		65			
	XV min./max.	82	72	96	82	107	88	117	90	132	91		
Y	Y ±2	50		60		62		67		71			
Z	Z	4°		4°		4°		4°		4°			
	ZB	121 + Hub		137 + Hub		166 + Hub		176 + Hub		185 + Hub			
	ZJ ±1	114 + Hub		128 + Hub		153 + Hub		159 + Hub		168 + Hub			
min.	Hub	10		14		19		27		41			
	Stroke MT4												
	Course												

Copyright by Hydraulika GmbH



Betriebsdruck max. 16 MPa (160 bar)

Operating pressure
Service de pression

03/03

5

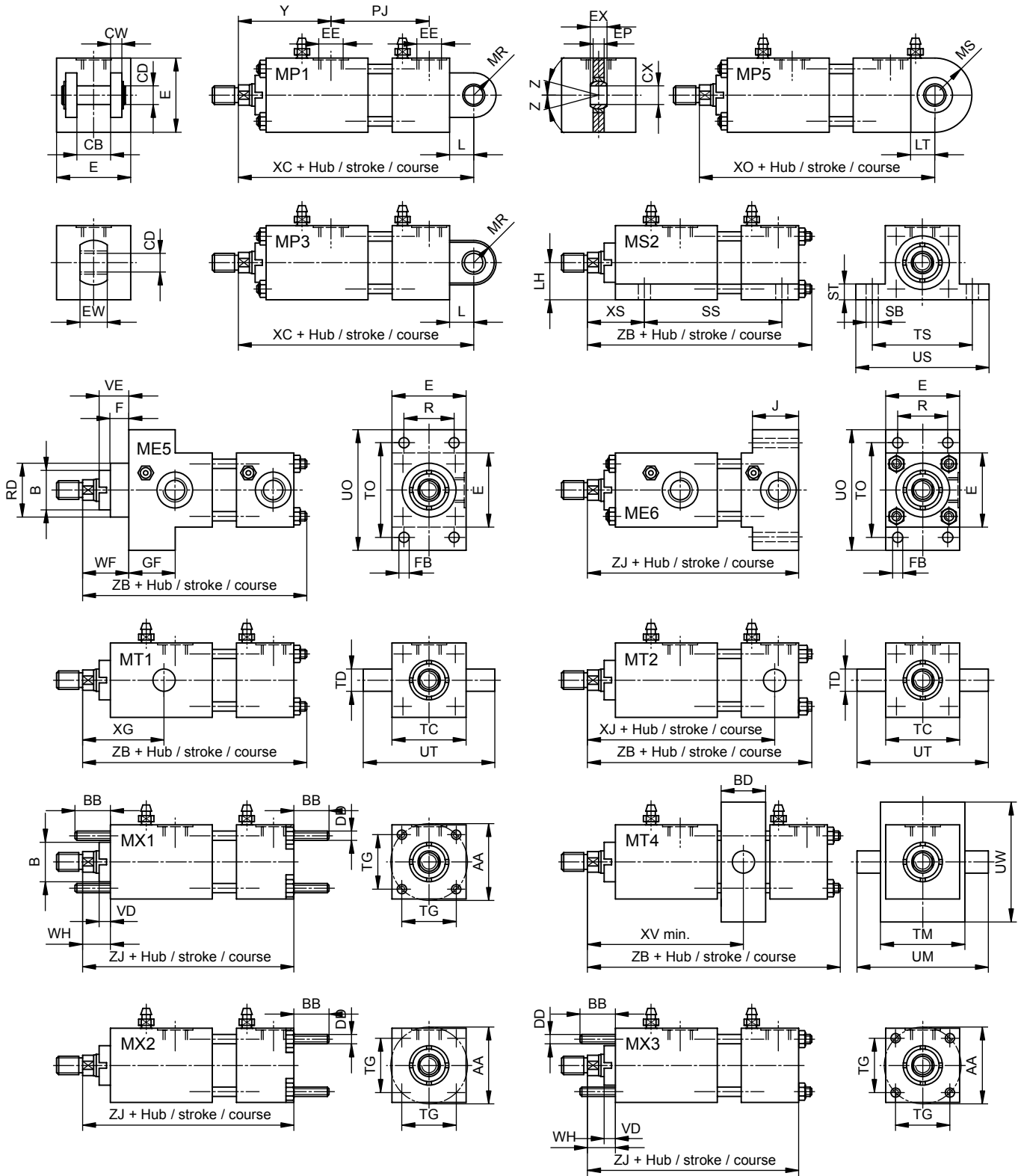

Kolbenstangenende STANDARD

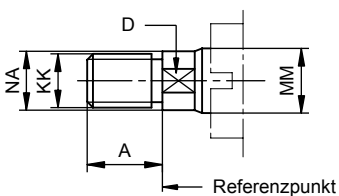

Kolbenstangenende mit Innengewinde
Kolben-Ø 25, 32, 40 nur starke Kolbenstange

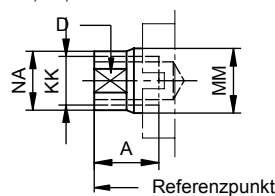

Lage der Anschlüsse

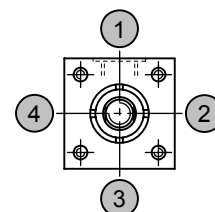

Nenn-Ø		80		100		125		160		200			
MM-Ø		36	56	45	70	56	90	70	110	90	140		
cm ²	Kolbenfläche	50,3		78,5		122,7		201,1		314,2			
	Kolbenringfläche	40,1	25,6	62,6	40,1	98,1	59,1	162,6	106,0	250,5	160,2		
		Hub = 0				Stroke = 0				Course = 0			
A	A h15	36	56	45	63	56	85	63	95	85	112		
	AA	117		137		178		219		269			
B	B f9	50	72	60	88	72	108	88	133	108	163		
	BB	59		59		81		92		115			
	BD	60		70		90		110		130			
C	CB	40		50		60		70		80			
	CD	28		36		45		56		70			
	CW	20		25		30		35		40			
	CX	40 -0,010		50 -0,012		60 -0,012		80 -0,015		100 -0,015			
D	D	30	48	39	62	48	80	62	100	80	128		
	DD	M16x1,5		M16x1,5		M22x1,5		M27x2		M30x2			
E	E	115		130		165		205		245			
	EE	G ¾"		G ¾"		G 1"		G 1"		G 1 ¼"			
	EP h15	23		30		38		47		57			
	EW h14	40		50		60		70		80			
	EX	28 -0,12		35 -0,12		44 -0,12		55 -0,15		70 -0,15			
F	F	20		20		22		25		25			
	FB H13	18		18		22		26		33			
G	GF	50		50		60		60		80			
J	J	45		45		58		58		76			
K	KK	M27x2	M42x2	M33x2	M48x2	M42x2	M64x3	M48x2	M80x3	M64x3	M100x3		
L	L	48		54		57		63		82			
	LH h10	57		63		82		101		122			
	LT	48		58		72		92		116			
M	MM	36	56	45	70	56	90	70	110	90	140		
	MR	34		50		53		59		78			
	MS	50		62		80		100		120			
N	NA	34	54	43	68	54	88	68	108	88	138		
P	PJ ±1,25	93 + Hub		101 + Hub		117 + Hub		130 + Hub		165 + Hub			
R	R js13	83		97		126		155		190			
	RD f8	82	105	92	125	105	150	125	170	150	210		
S	SB H13	18		26		26		33		39			
	SS ±1,25	105 + Hub		102 + Hub		131 + Hub		130 + Hub		172 + Hub			
	ST	26		32		32		38		44			
T	TC h14	114		127		165		203		241			
	TD f8	40		50		63		80		100			
	TG	82,7		96,9		125,9		154,9		190,2			
	TM h14	127		140		178		215		279			
	TO js13	149		162		208		253		300			
	TS js13	149		172		210		260		311			
U	UM	191		220		278		341		439			
	UO	180		200		250		300		360			
	US	186		216		254		318		381			
	UT	178		207		265		329		401			
	UW	160		180		215		260		355			
V	VD min.	5		5		5		5		5			
	VE	29		32		32		32		32			
W	WF ±2	51		57		57		57		57			
	WH ±2	31		35		35		32		32			
X	XC ±1,25	229 + Hub		257 + Hub		273 + Hub		308 + Hub		381 + Hub			
	XG	76		71		75		75		85			
	XJ	168 + Hub		187 + Hub		209 + Hub		230 + Hub		276 + Hub			
	XO ±1,25	238 + Hub		261 + Hub		304 + Hub		337 + Hub		415 + Hub			
	XS ±2	68		79		79		86		92			
	XV min./max.	147	99	158	107	180	109	198	104	225	130		
Y	Y ±2	77		82		86		86		98			
Z	Z	4°		4°		4°		4°		4°			
	ZB	212 + Hub		225 + Hub		260 + Hub		279 + Hub		336 + Hub			
	ZJ ±1	190 + Hub		203 + Hub		232 + Hub		245 + Hub		299 + Hub			
min.	Hub	48		51		71		94		96			
	Stroke MT4												
	Course												

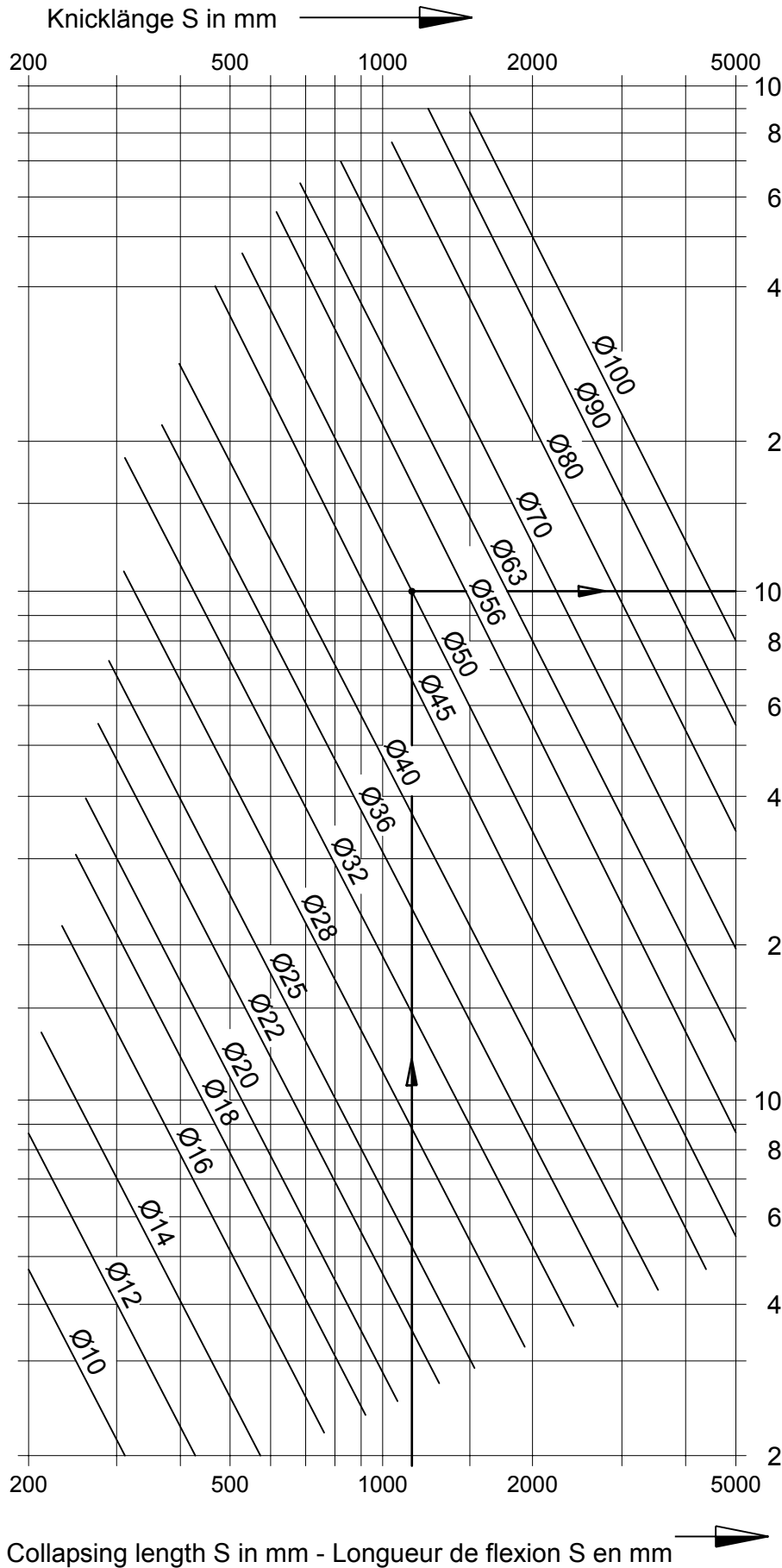

L = ausgefahren /
extended / déployé

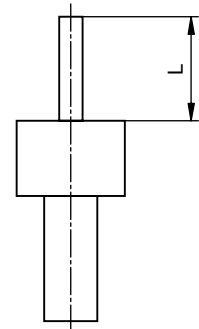

Diagrammwert S = L
value of diagram
valeur du diagramme

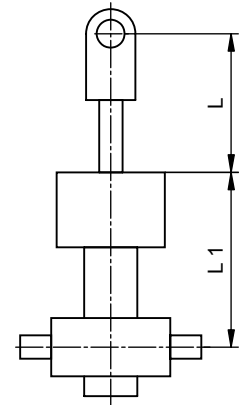

Diagrammwert $S = \frac{L_1}{1,3} + L$
value of diagram
valeur du diagramme

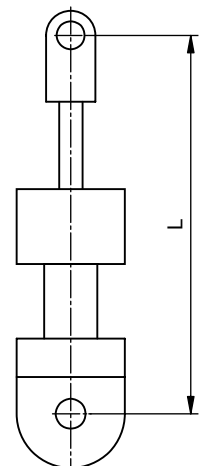

Diagrammwert $S = \frac{L}{1,3}$
value of diagram
valeur du diagramme

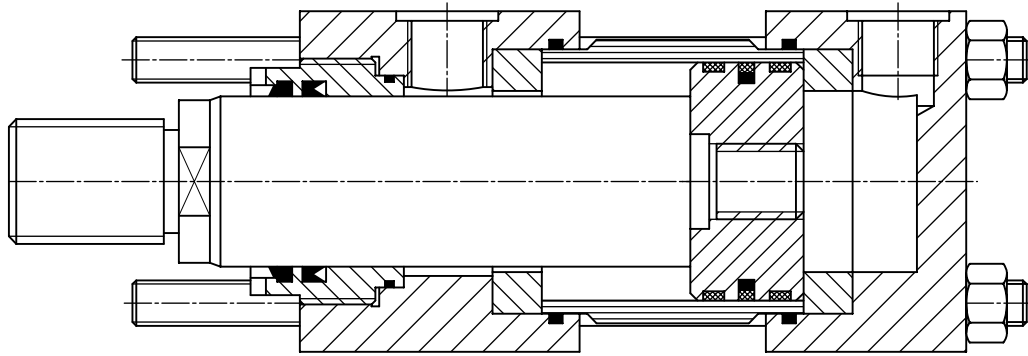

Kolben-Ø - Stangen-Ø
Piston diam. - piston rod diam.

Kolben-Ø - Stangen-Ø
Piston diam. - piston rod diam.

Dichtsatz
Seal kit
Joint de pochettes

Dichtsatz Viton
Seal kit "VITON"
Joint de pochettes "VITON"

Dämpfungsschraube
Damping screw
Standard

Dämpfungsschraube
Damping screw
"VITON"

25/12		26EP1		26EV1		42519901	42519911
	25/18		26EP2		26EV2		
32/14		26FP1		26FV1		42519901	42519911
	32/22		26FP2		26FV2		
40/18		26GP1		26GV1		42519901	42519911
	40/28		26GP2		26GV2		
50/22		26HP1		26HV1		42519901	42519911
	50/36		26HP2		26HV2		
63/28		26KP1		26KV1		42519901	42519911
	63/45		26KP2		26KV2		
80/36		26MP1		26MV1		42519901	42519911
	80/56		26MP2		26MV2		
100/45		26OP1		26OV1		42519901	42519911
	100/70		26OP2		26OV2		
125/56		26SP1		26SV1		42519901	42519911
	125/90		26SP2		26SV2		
160/70		26TP1		26TV1		42519901	42519911
	160/110		26TP2		26TV2		
200/90		26UP1		26UV1		42519901	42519911
	200/140		26UP2		26UV2		