

**HYDRAULIKA**

**DIN 24554**

# **ZN 160.D**

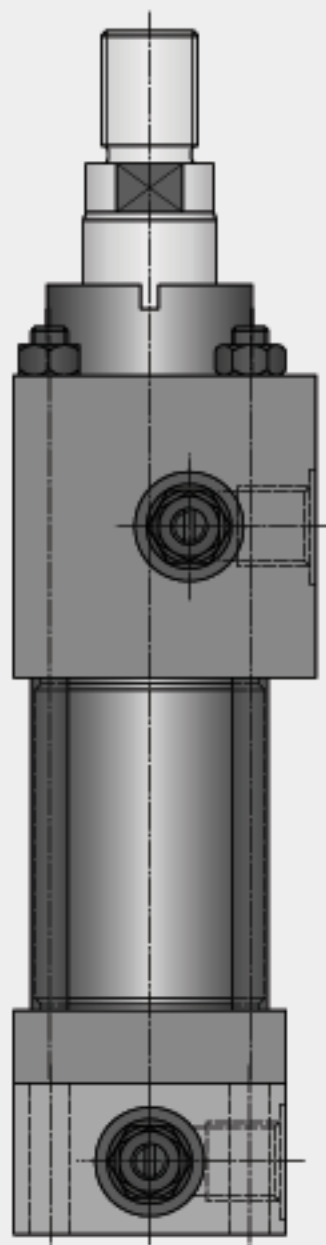
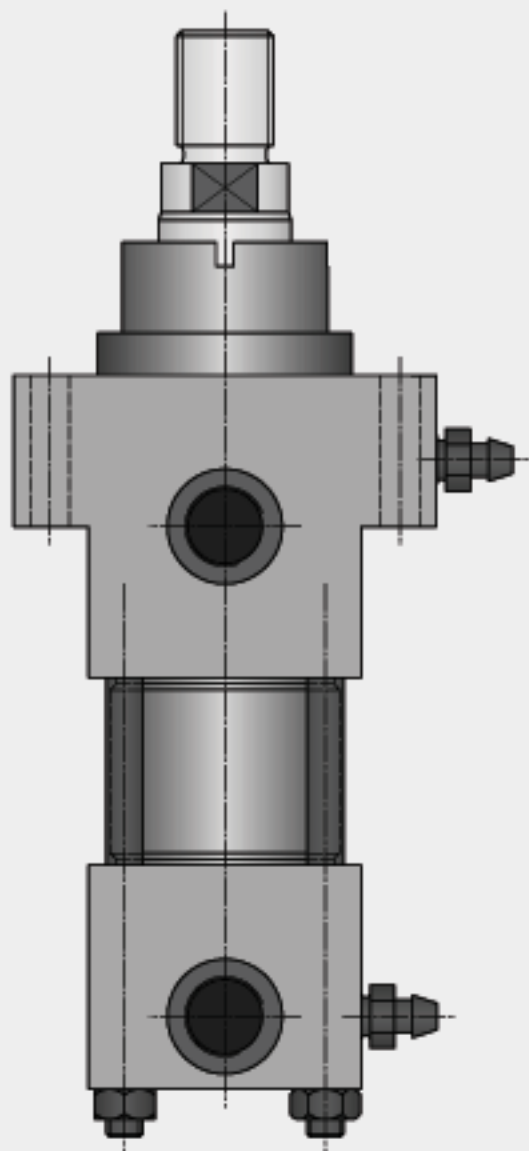

**Hydraulika GmbH**  
Stübeweg 54  
D - 79108 Freiburg

Tel.: +49 (0) 761 / 504710  
Fax.: +49 (0) 761 / 5047199

e - mail : [info@hydraulika.de](mailto:info@hydraulika.de)

Alleinige Herstellerin der  
Markenerzeugnisse

**HYDAIR**<sup>®</sup>

Universalzylinder für Luft- oder Ölbetrieb  
Universal cylinder for air or hydraulic operation  
Cylindre universel pour service d'air ou service hydraulique

Hydraulikzylinder  
Hydraulic cylinder  
Cylindre hydraulique

DIN / ISO - Zylinder  
DIN / ISO - Cylinders  
DIN / ISO - Cylindre

Zylinder mit induktiver Endlagenabfrage  
Cylinders with inductive proximity sensors  
Cylindres avec détecteurs de proximité inductifs

Zylinder mit Wegmess - Systemen  
Cylinders with position transducer  
Cylindres avec transducteur de position

Pneumatikzylinder  
Air cylinder  
Cylindre à air

Block - und Einschraubzylinder  
Block - and Screw-in Cylinders  
Monobloc - et Cylindres à visser

Sonderzylinder                    auf Anfrage  
Special Cylinders                on request  
Cylindres spéciaux                à demande

Drehantriebe pneumatisch bzw. hydraulisch  
Rotating drives for pneumatic or hydraulic  
Mécanismes de commande rotatifs pneumatique ou hydraulique

Druckübersetzer pneumatisch - hydraulisch  
Pressure intensifier  
Transformateur de pression

Verbindungselemente / Zubehör  
Connecting parts / Fittings  
Éléments de fixation / Accessoires

**Die Hydraulika Normzylinder ZN**

Baureihe ZN 160.D entspricht in allen Belangen und Anforderungen der internationalen Normung für Hydrozylinder

**ZN 160.D - 160 bar -  
DIN 24554**

Alle Zylinder sind wahlweise mit oder ohne Endlagendämpfung lieferbar, wobei die Einbaumaßnahmen gleich bleiben. Die Endlagendämpfung ist ab Kolben-Ø 40 serienmässig regelbar mit freiem Rücklauf.

Entlüftungsschrauben serienmässig

Durch das Baukastenprinzip sind nahezu alle Befestigungsteile mit dem Grundzylinder montierbar, dadurch ist auch die Lieferung von Zylinder- Einzelteilen ( Komponenten ) zur Selbstmontage möglich.

Die Hublängen werden nach Kundenwunsch gefertigt, dabei ist jedoch die Knickbelastung der Kolbenstange gemäss Diagramm zu beachten.

Zu jedem Kolben-Ø sind wahlweise zwei Stangen-Ø lieferbar. Die Kolbenstangen- gewinde sind zum Anbau der passenden Gelenkköpfe vorgesehen.

Die Kolbenstangen werden standardmässig aus Vergütungsstahl mit hartverchromter Oberfläche gefertigt - auf Wunsch auch induktivgehärtet und hartverchromt lieferbar.

Alle Zylinder sind standardmässig mit PUR - Nutring als Stangendichtung, PTFE- Gleitring-Dichtsatz als Kolbendichtung, sowie reibungsarmen und verschleissfesten PTFE - Compound-Führungselementen ausgerüstet. Andere Dichtungsvarianten sind auf Wunsch lieferbar.

Betriebsmedium Mineralöl nach DIN 51524 und DIN 51525. Bei anderen Druckmedien wird um Rücksprache gebeten.

Betriebstemperaturbereich  
-35°C bis +110°C

Max. Gleitgeschwindigkeit 0,5 m/s

Andere Ausführungen auf Anfrage.

**The Hydraulika**

**Standard Cylinders ZN**

Serie ZN 160.D completely fulfill the requirements of the international Standards for Hydraulic cylinders:

**ZN 160.D - 160 bar -  
DIN 24554**

As required, all cylinders are available with or without final position damping, with the installation dimensions remaining the same. As standard, the final position damping is adjustable on piston- diam. 40, with free return.

Venting bolts standard

Due to the modular principle, virtually all mounting parts can be fitted with the basic cylinder, and it is thus possible to supply individual cylinders parts ( components ), for self- assembly.

The stroke lengths are made according to the customers requirements, provided the strain resistance of the piston rod is observed, according to the diagram.

For each piston dia., two rod diameters are available, as required. The piston rod threads are designed for the fitment of suitable articulated heads.

As standard, the piston rods are manufactured from heat treated steel with hardchromium plated surface, on request, induction hardened and hardchromium plating is also available.

As standard, all cylinders are fitted with a PUR groove ring as the rod seal, PTFE slide ring packing as the piston seal, as well as low- friction, wearresistant PTFE compound guide elements. Other sealing variants are available on request.

Operating medium Mineral oils according to DIN 51524 and DIN 51525. Please contact us if you like to use other fluids.

Operating temperature range  
-35°C to +110°C .

Max. rubbing speed 0,5 m/s

Other versions are possible on request.

**Les cylindres standard**

**Hydraulika ZN**

des série ZN 160.D correspondent sous tous les aspects aux exigences des normes internationales relatives aux cylindres hydrauliques :

**ZN 160.D - 160 bar -  
DIN 24554**

Tous les cylindres peuvent être livrés, à choix du client, avec ou sans amortissement de positions finales, les dimensions restant toujours les mêmes. L'amortissement des positions finales est réglable sur tous les types de série; recul libre.

Vis de purge d'air

Grâce au principe modulaire, presque tous les éléments de fixation peuvent être montés avec le cylindre standard; ce système-là permet aussi la fourniture d'éléments individuels de cylindres ( composants ) à monter par le client même.

Les longueurs de course seront adaptées aux besoins du client, tout en tenant compte de l'effort de flexion auquel sera soumise la tige du piston et qui résulte du schéma.

Chaque Ø de piston peut être combiné avec deux Ø de tige. Les filets des tiges de piston sont destinés à recevoir les têtes articulées correspondantes.

Les tiges de piston standard sont fabriquées d'acier trempé à surface au chromage dur; à demande du client, fabrication par trempe inductive et chromage dur.

Tous les cylindres sont équipés, en série, d'anneaux à rainures PUR servant de garniture de la tige, d'anneaux de glissement PTFE servant de garniture de piston, et d'éléments de guidage compound PTFE à faible frottement et résistants à l'usure. Autres types de garnitures livrables à demande.

Operating medium Mineral oils according to DIN 51524 and DIN 51525. Please contact us if you like to use other fluids.

Températures de service:  
de -35°C à +110°C .

Vitesse de glissement max.: 0,5m/s

Des autres modèles à demande.

**Bestellbeispiel / Order example / Exemple de commande**

**ZN 160.D - MS 2 50 / 36 / 110 Dbb**

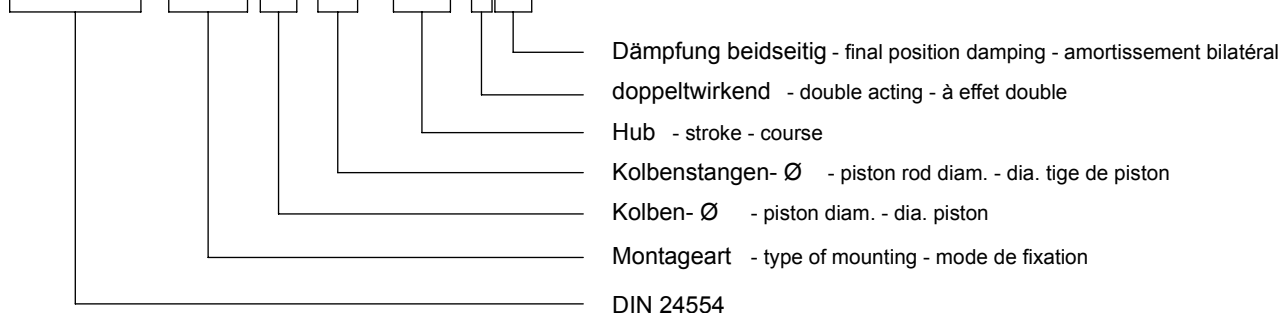

Copyright by Hydraulika GmbH



**Betriebsdruck max. 16 MPa ( 160 bar )**  
Operating pressure  
Service de pression

10/01

3

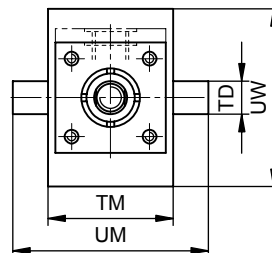
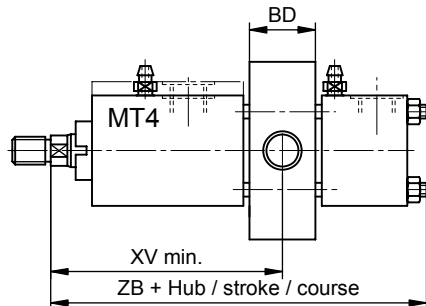
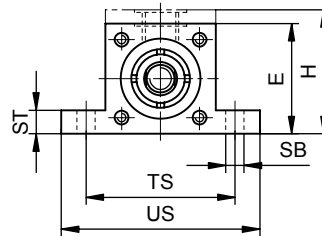
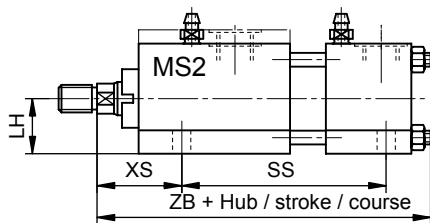
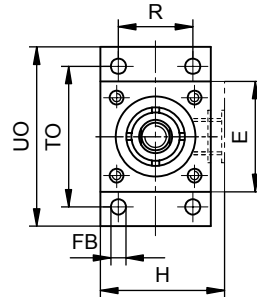
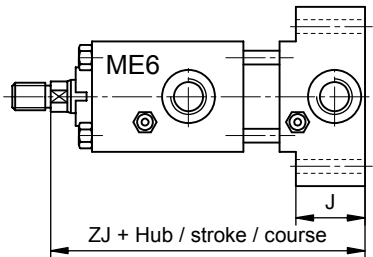
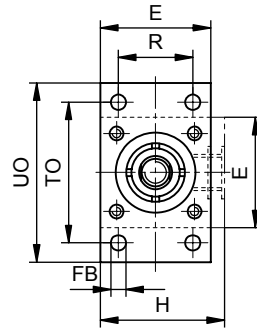
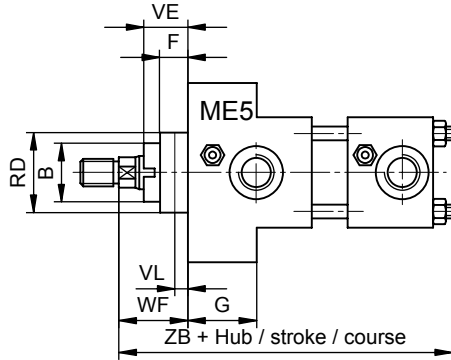
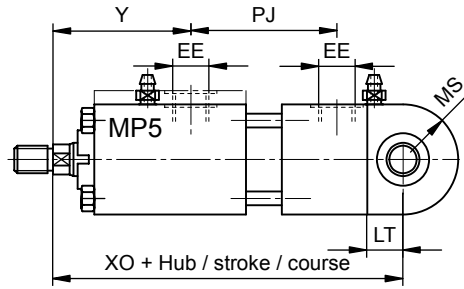
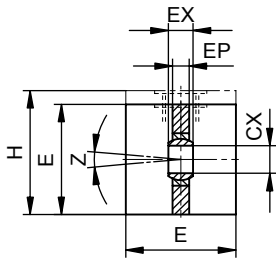

**Kolbenstangenende STANDARD**

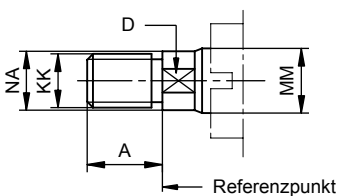

**Kolbenstangenende mit Innengewinde**  
Kolben-Ø 25, 32, 40 nur starke Kolbenstange

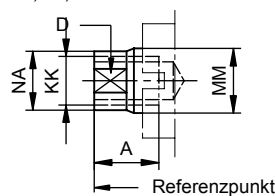

**Lage der Anschlüsse**

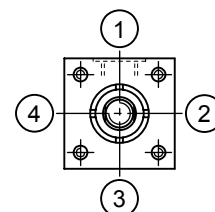

Änderungen vorbehalten  
Subject to change  
Sous réserve de modification

Masse  
Measures  
Mesures

**ZN 160.D**  
**DIN 24554**

Nenn-Ø		25		32		40		50		63			
MM-Ø		12	18	14	22	18	28	22	36	28	45		
cm <sup>2</sup>	Kolbenfläche	4,9		8,0		12,6		19,6		31,2			
	Kolbenringfläche	3,8	2,4	6,5	4,2	10,0	6,4	15,8	9,5	25,0	15,3		
		Hub = 0				Stroke = 0				Course = 0			
A	h15	14		16		18		22		28			
B	f9	24	30	26	34	30	42	34	50	42	60		
BD		20		25		30		40		50			
CX		12 -0,008		16 -0,008		20 -0,012		25 -0,012		30 -0,012			
D		10		12		15		18		22			
E		40		45		63		75		90			
EE		G 1/4"		G 1/4"		G 3/8"		G 1/2"		G 1/2"			
EP	h15	8 -0,12		11 -0,12		13 -0,12		17 -0,12		19 -0,12			
EX		10		14		16		20		22			
F		10		7		10		16		16			
FB		5,5		6,6		11		14		14			
GF	H13	25		25		38		38		38			
H		45		50		-		-		-			
J		25		25		38		38		38			
KK		M10x1,25		M12x1,25		M14x1,5		M16x1,5		M20x1,5			
LH	h10	19		22		31		37		44			
LT		16		20		25		31		38			
MS		20		22		29		32		45			
PJ	±1,25	53 + Hub		56 + Hub		73 + Hub		74 + Hub		80 + Hub			
R	js13	27		33		41		52		65			
RD	f8	38		42		62		74		75	88		
SB	H13	6,6		9		11		14		18			
SS	±1,25	73 + Hub		73 + Hub		98 + Hub		92 + Hub		86 + Hub			
ST		8,5		12,5		12,5		19		26			
TD	f8	12		16		20		25		32			
TM	h14	48		55		76		89		100			
TO	js13	51		58		87		105		117			
TS	js13	54		63		83		102		124			
UM		68		79		108		129		150			
UO		65		70		110		130		145			
US		72		84		103		127		161			
UW		63		75		92		112		126			
VE		16		22		22		25		29			
VL		3		3		3		4		4			
WF	±2	25		35		35		41		48			
XO	±1,25	130 + Hub		148 + Hub		178 + Hub		190 + Hub		206 + Hub			
XS	±2	33		45		45		54		65			
XV	min.	82		96		107		117		132			
Y	±2	50		60		62		67		71			
Z		3°		3°		3°		3°		3°			
ZB		121 + Hub		137 + Hub		166 + Hub		176 + Hub		185 + Hub			
ZJ	±1	114 + Hub		128 + Hub		153 + Hub		159 + Hub		168 + Hub			
Hub													
MT 4	Stroke min.	10		14		19		27		41			
	Course												

Copyright by Hydraulika GmbH

**HYDRAULIKA**

Betriebsdruck max. 16 MPa ( 160 bar )

Operating pressure  
Service de pression

03/03

5

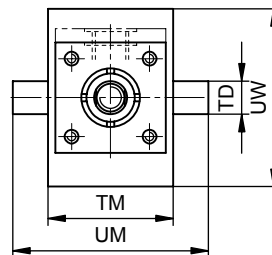
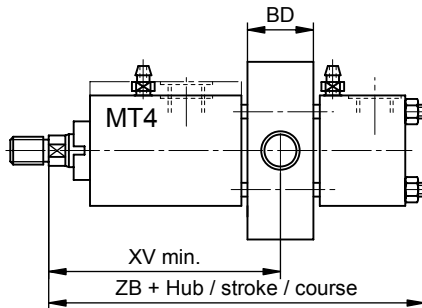
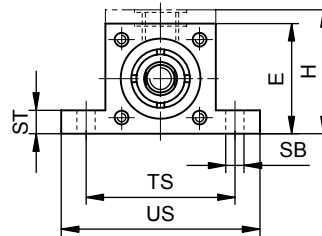
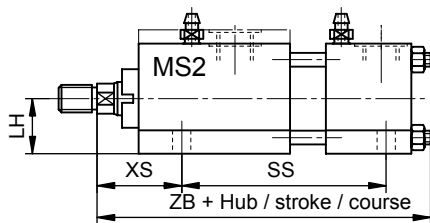
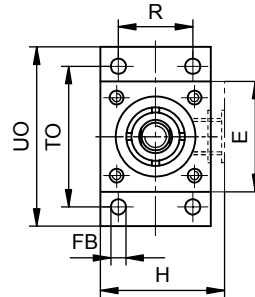
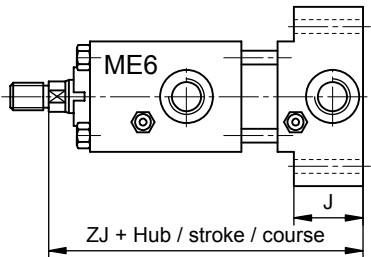
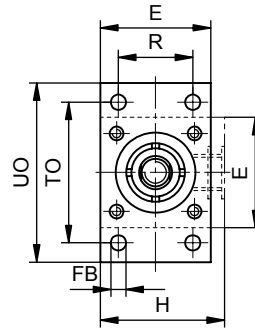
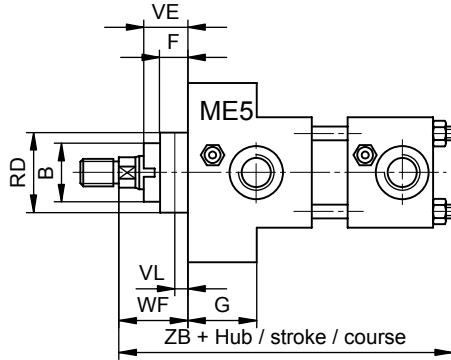
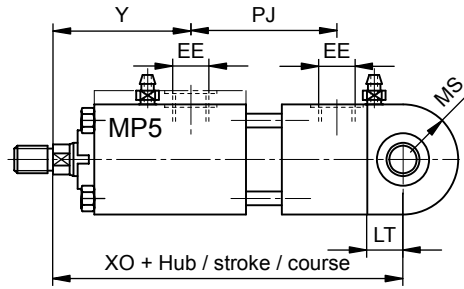
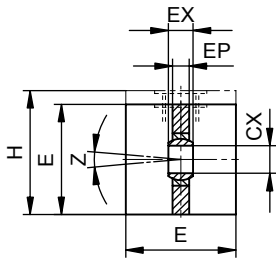

**Kolbenstangenende STANDARD**

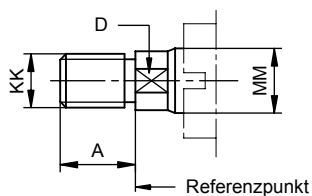

**Kolbenstangenende mit Innengewinde**  
Kolben-Ø 25, 32, 40 nur starke Kolbenstange

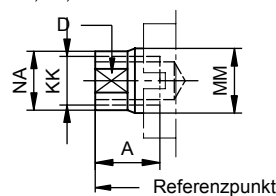

**Lage der Anschlüsse**

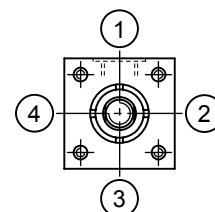

Nenn-Ø		80		100		125		160		200			
MM-Ø		36	56	45	70	56	90	70	110	90	140		
cm <sup>2</sup>	Kolbenfläche	50,3		78,5		122,7		201,1		314,2			
	Kolbenringfläche	40,1	25,6	62,6	40,1	98,1	59,1	162,6	106,0	250,5	160,2		
		Hub = 0				Stroke = 0				Course = 0			
A	h15	36		45		56		63		85			
B	f9	50	72	60	88	72	108	88	133	108	163		
BD		60		70		90		110		130			
CX		40 -0,012		50 -0,012		60 -0,015		80 -0,015		100 -0,020			
D		30	48	39	62	48	80	62	100	80	128		
E		115		130		165		205		245			
EE		G 3/4"		G 3/4"		G 1"		G1"		G 1 1/4"			
EP	h15	23		30		38		47		57			
EX		28 -0,12		35 -0,12		44 -0,15		55 -0,15		70 -0,20			
F		20		22		22		25		25			
FB		18		18		22		26		33			
GF	H13	45		45		58		58		76			
H		-		-		-		-		-			
J		45		45		58		58		76			
KK		M27x2		M33x2		M42x2		M48x2		M64x3			
LH	h10	57		63		82		101		122			
LT		48		58		72		92		116			
MS		50		62		80		100		120			
PJ	±1,25	93 + Hub		101 + Hub		117 + Hub		130 + Hub		165 + Hub			
R	js13	83		97		126		155		190			
RD	f8	82	105	92	125	105	150	125	170	150	210		
SB	H13	18		26		26		33		39			
SS	±1,25	105 + Hub		102 + Hub		121 + Hub		130 + Hub		172 + Hub			
ST		26		32		32		38		44			
TD	f8	40		50		63		80		100			
TM	h14	127		140		178		215		279			
TO	js13	149		162		208		253		300			
TS	js13	149		172		210		260		311			
UM		191		220		278		341		439			
UO		180		200		250		300		360			
US		186		216		254		318		381			
UW		160		180		215		260		355			
VE		29		32		32		32		32			
VL		4		5		5		5		5			
WF	±2	51		57		57		57		57			
XO	±1,25	238 + Hub		261 + Hub		304 + Hub		337 + Hub		415 + Hub			
XS	±2	68		79		79		86		92			
XV	min.	147		158		180		198		225			
Y	±2	77		82		86		86		98			
Z		3°		3°		3°		3°		3°			
ZB		212 + Hub		225 + Hub		260 + Hub		279 + Hub		336 + Hub			
ZJ	±1	190 + Hub		203 + Hub		232 + Hub		245 + Hub		299 + Hub			
Hub													
MT 4	Stroke min.	48		51		71		94		96			
	Course												

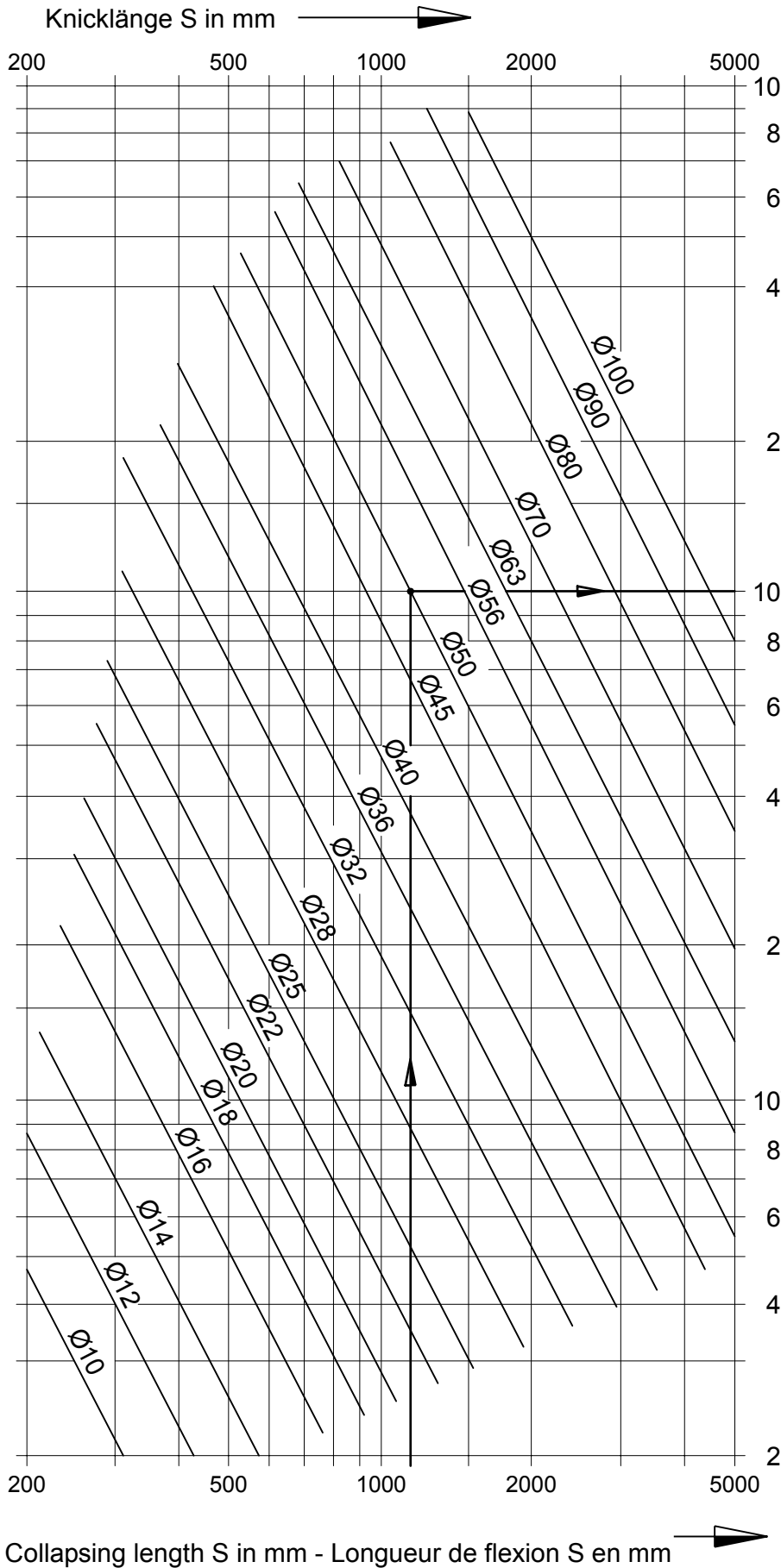

L = ausgefahren /  
extended / déployé

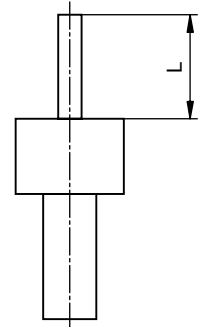

Diagrammwert S = L  
value of diagram  
valeur du diagramme

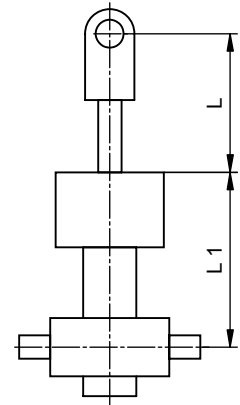

Diagrammwert  $S = \frac{L1}{1,3} + L$   
value of diagram  
valeur du diagramme

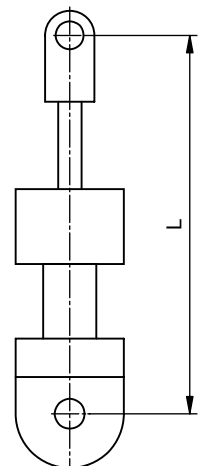

Diagrammwert  $S = \frac{L}{1,3}$   
value of diagram  
valeur du diagramme

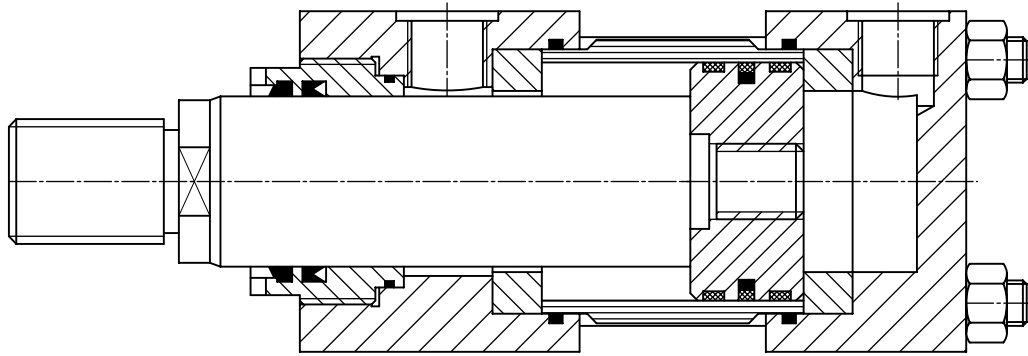

*Kolben-Ø - Stangen-Ø*  
*Piston diam. - piston rod diam.*

*Kolben-Ø - Stangen-Ø*  
*Piston diam. - piston rod diam.*

*Dichtsatz*  
*Seal kit*  
*Joint de pochettes*

*Dichtsatz Viton*  
*Seal kit "VITON"*  
*Joint de pochettes "VITON"*

*Dämpfungsschraube*  
*Damping screw*  
*Standard*

*Dämpfungsschraube*  
*Damping screw*  
*"VITON"*

25/12		26EP1		26EV1		42519901	42519911
	25/18		26EP2		26EV2		
32/14		26FP1		26FV1		42519901	42519911
	32/22		26FP2		26FV2		
40/18		26GP1		26GV1		42519901	42519911
	40/28		26GP2		26GV2		
50/22		26HP1		26HV1		42519901	42519911
	50/36		26HP2		26HV2		
63/28		26KP1		26KV1		42519901	42519911
	63/45		26KP2		26KV2		
80/36		26MP1		26MV1		42519901	42519911
	80/56		26MP2		26MV2		
100/45		26OP1		26OV1		42519901	42519911
	100/70		26OP2		26OV2		
125/56		26SP1		26SV1		42519901	42519911
	125/90		26SP2		26SV2		
160/70		26TP1		26TV1		42519901	42519911
	160/110		26TP2		26TV2		
200/90		26UP1		26UV1		42519901	42519911
	200/140		26UP2		26UV2		